

## Assembly instructions

SF 25 / SF 35

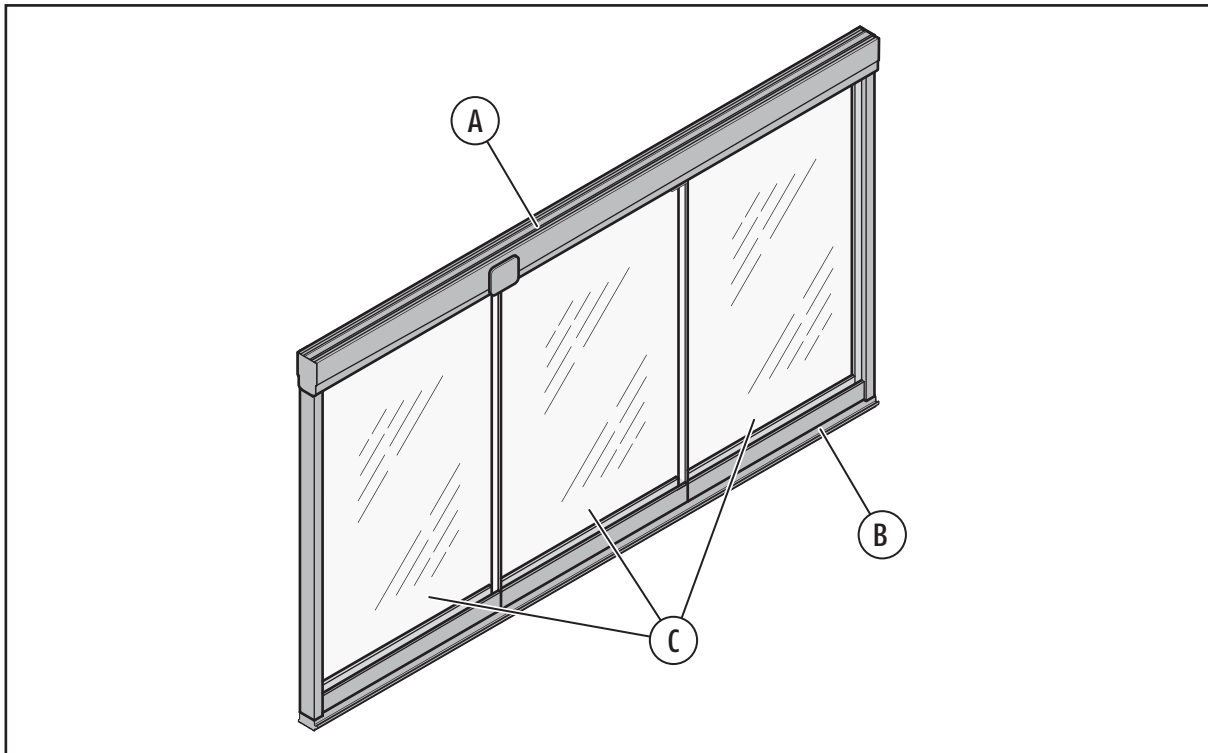

### Scope of delivery:

- A. Upper rail, height compensation profile  
(coupled, do not separate)
- B. Floor rail
- C. Sliding panel
- Accessories pack

### Safety instructions:

These assembly instructions are specifically designed for the use of authorised specialists. Observation and implementation of the relevant safety regulations are a prerequisite.

### Symbols used:



Caution



Note

### Tools required:

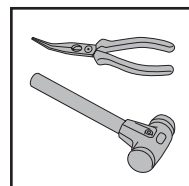
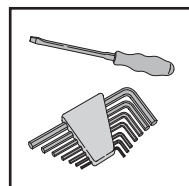
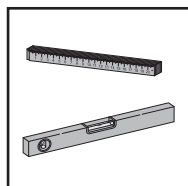
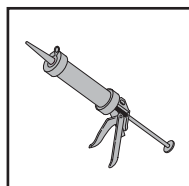
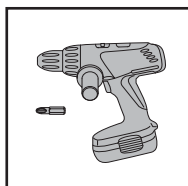
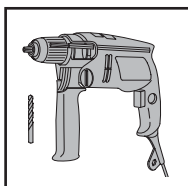

# Index



Description	Page
01. Assembly of frame	3
01a. Corner connection (angle-type systems)	4
01b. Straight connection (for systems with excess length)	5
02. Assembly of upper rail	6
03. Arrangement of lower rail (weathered rail)	7, 8
04. Fitting of panel	8
05. Arrangement of inset floor rail (optional)	9, 10, 11
06. Assembly of guide elements	12
07. Adjustment	13
08. Accessory assembly	14
09. Assembly of seal reception profile	15
10. Safety advice	16
11. Handling	17
12. Maintenance and servicing instructions	18, 19



## Important:

After successful assembly the fitter must give instructions to the customer in order to avoid incorrect operation.

## 01. Assembly of frame



Only for systems with lateral vertical frame!  
Note lower/upper mounting shoe!

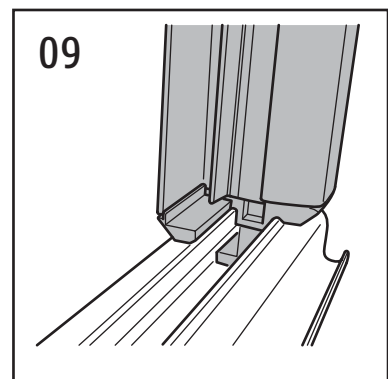
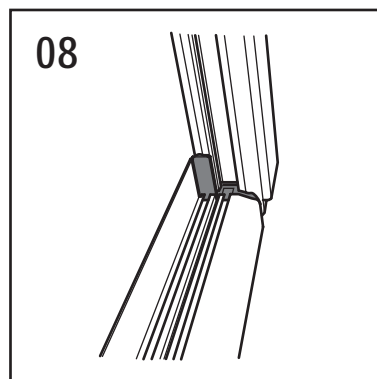
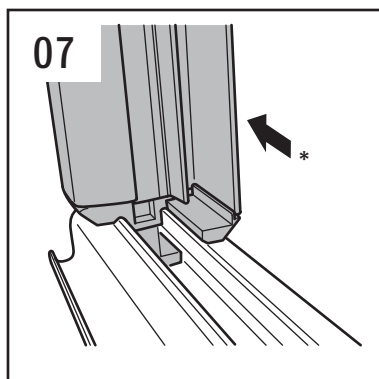
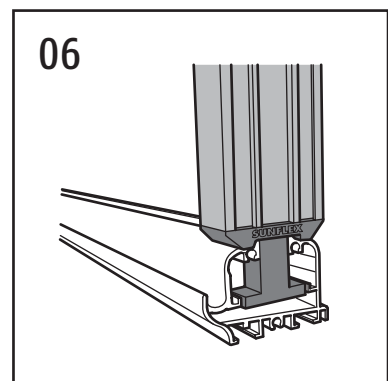
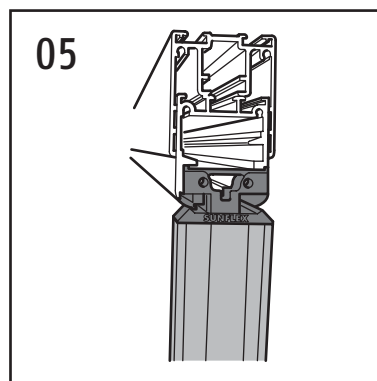
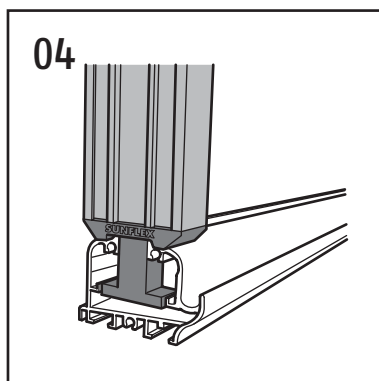
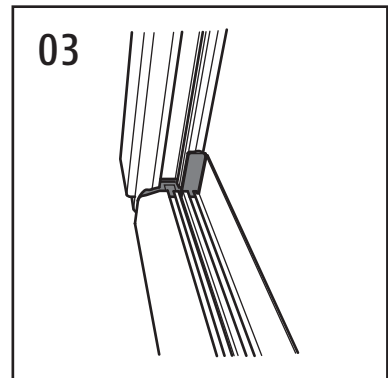
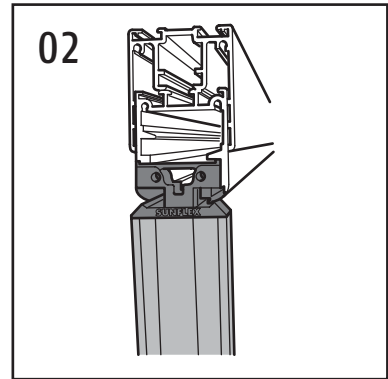
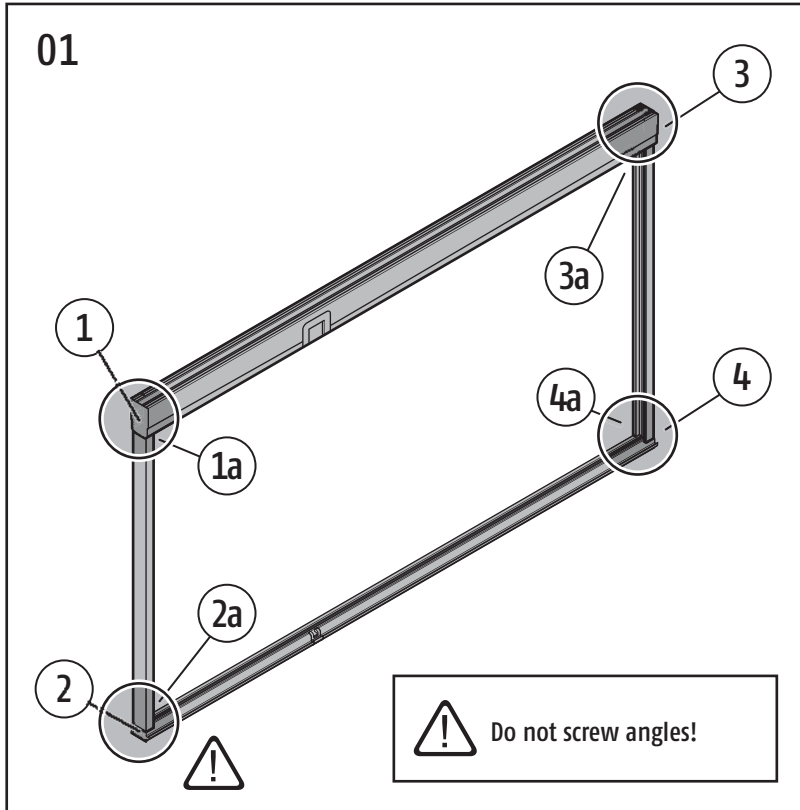

Outside for inside folding! Inside for outside folding\*

01a. Corner connection 90° (angle-type systems)

10

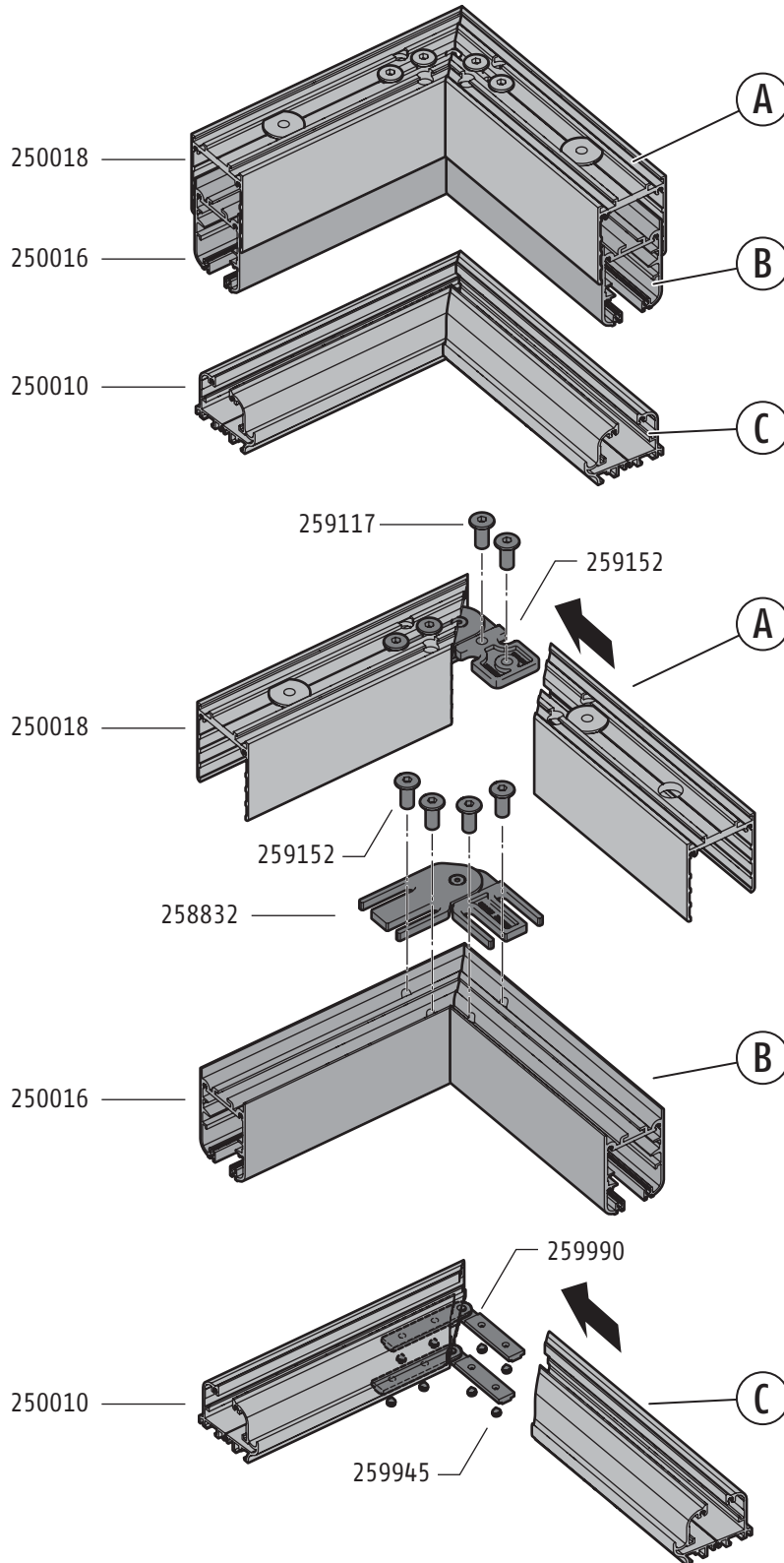

01b. Straight connection (for systems with excess length)

11

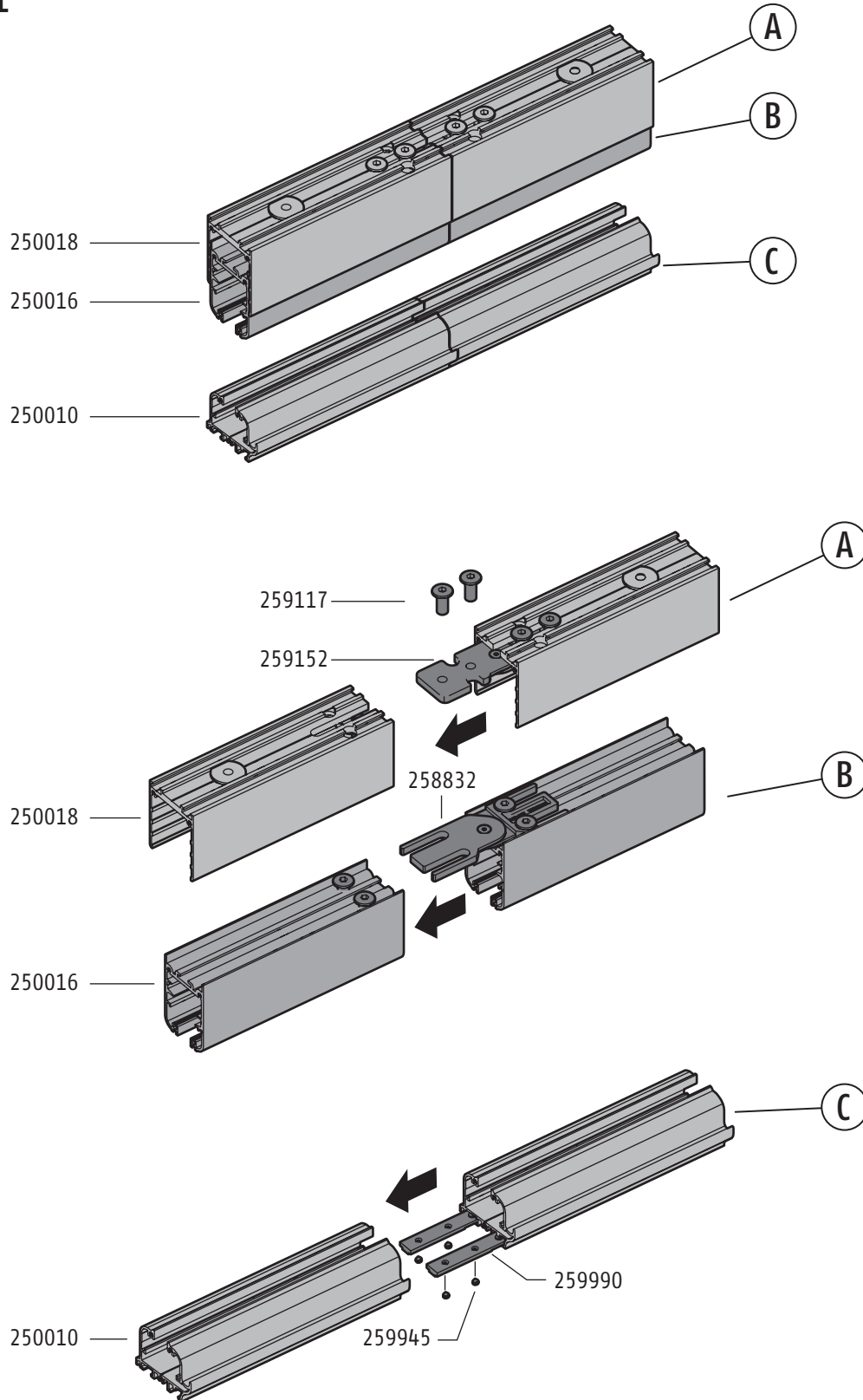

## 02. Assembly of upper rail



The rail and height compensation profiles are pre-mounted with intermediate setting dimensions and must NOT be separated from each other!

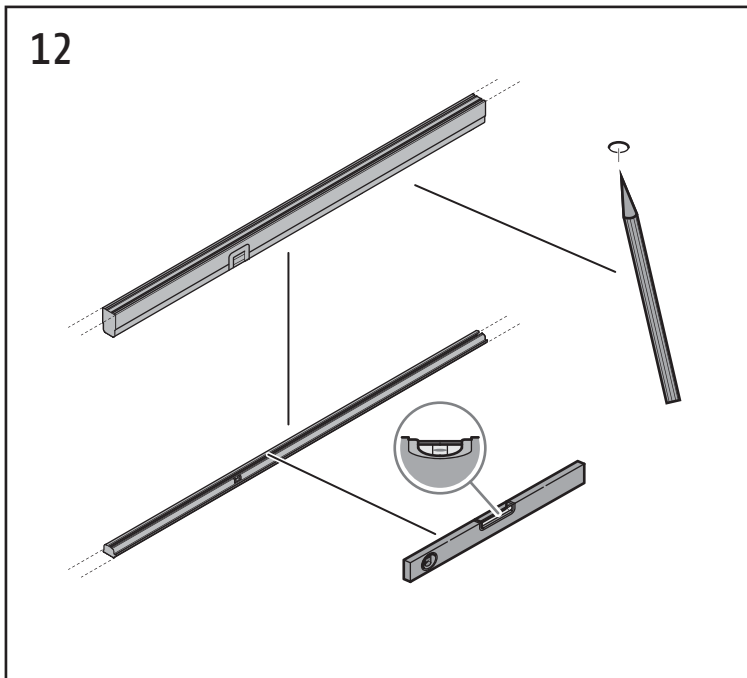

- Place the top rail (including HAP) on the unit and mark out the drill holes.
- Place ceiling rail to one side.
- Pre-drill holes for anchor and insert anchor (we recommend heavy load anchors with good shear and tensile strength qualities, screw head max. diameter 14 mm).
- Now fit ceiling rail horizontally with respect to the ceiling clearance (approx 5mm).
- Lay the floor rail in the structural opening.
- Determine the position of the rail and arrange it horizontally at an appropriate distance to the ceiling rail (panel height + 10 mm).

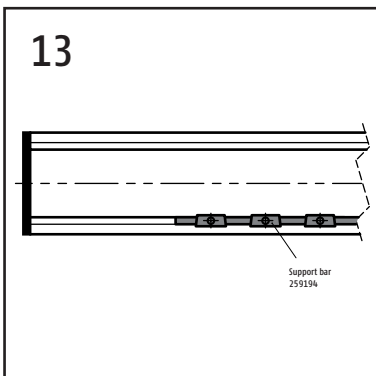

- Remove support bar (259194) above recess before mounting turn panel.
- Reinsert support bar after mounting and securing turn panel.

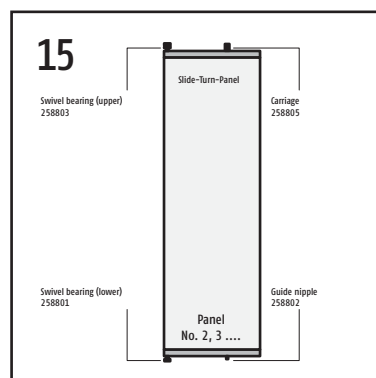
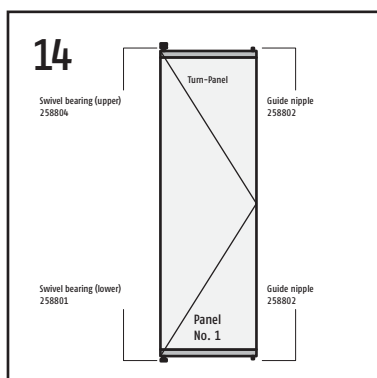

Illustrations show panel types.

## 03. Arrangement of lower rail (weathered rail)

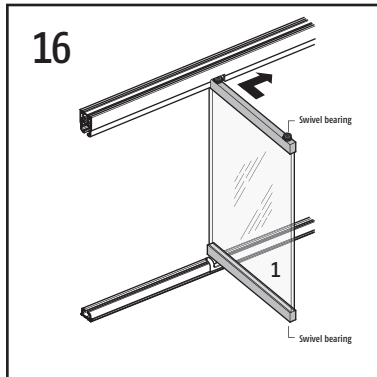

- Insert panel 1 (swivel panel) into the rails through the inspection openings with the stop stud leading as shown in the diagram. Locate clear of the swivel point, insert the ball bearing and the swivel bearing into the rails and then push the complete panel towards the swivel point.



Please note particular attention to the following points in order to avoid incorrect installation!

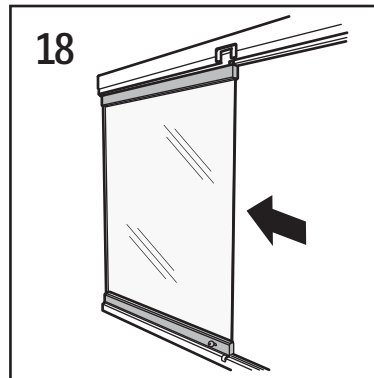
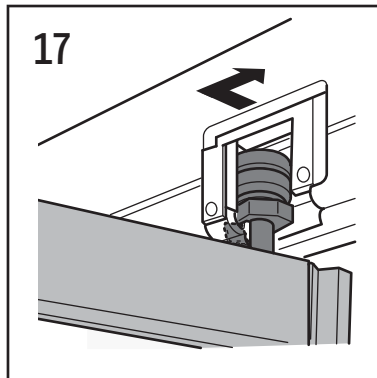

- Insert the swivel bearing (258804) through the recess at the top of the ceiling track. The bar must point towards to the opening direction.
- Bar is positioned 90° to rail.
- Slide panel towards the hinge whilst turning.

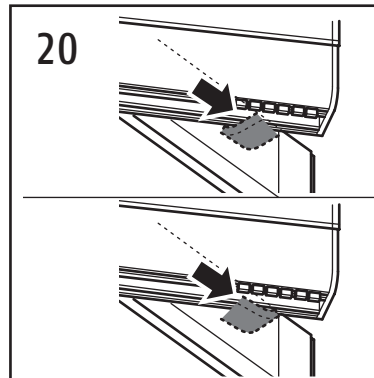
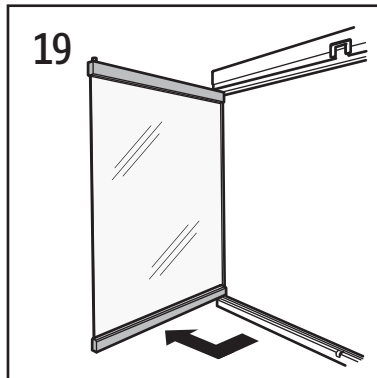

- Slide to stop and secure by turning the bar, see illustration (19).
- Turn bar by 90° inwards (towards recess) until it is positioned lengthways in the rail.

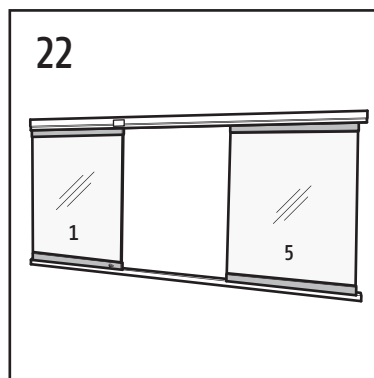
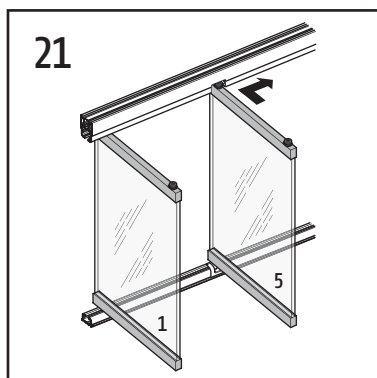

- Loosen delimiter (259965) in the the lower floor rail and displace by about 1 panel width in the direction to the centre of the system.
- Fit panel No 5 (with the carriage leading) and slide towards the rail end.
- By sliding the floor rail right or left the panel can now be set exactly vertical.

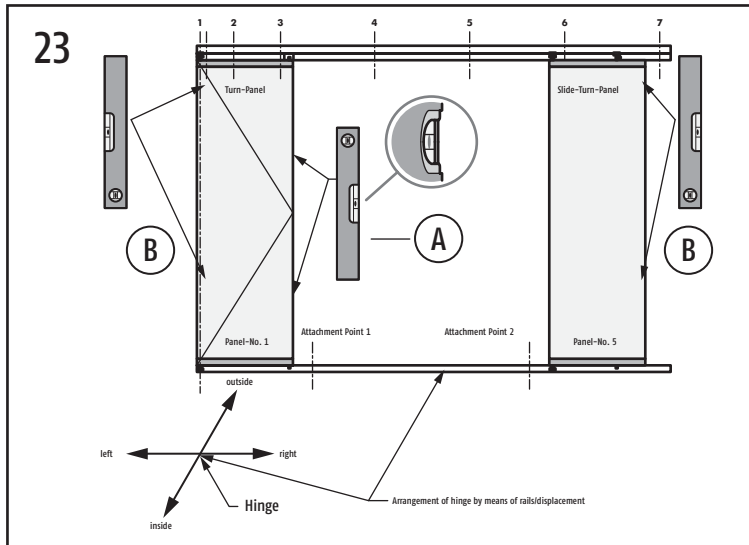

A = Movement right/left by means of spirit level on glass edge and by laying the floor rail on the wall side.

B = Movement inside/outside by means of spirit level on glass edge right and left.



For the follow steps the swivel panel must be supported when open!

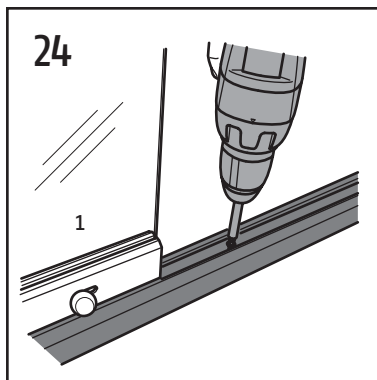

• Attachment of floor rail next to closed panel 1.

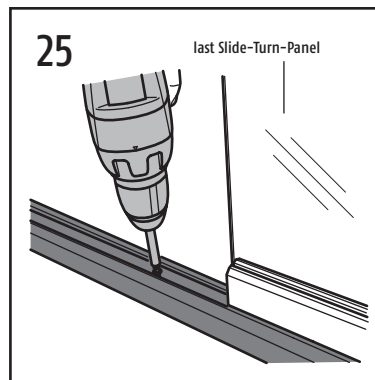

• Attachment of floor rail next to closed panel 2.

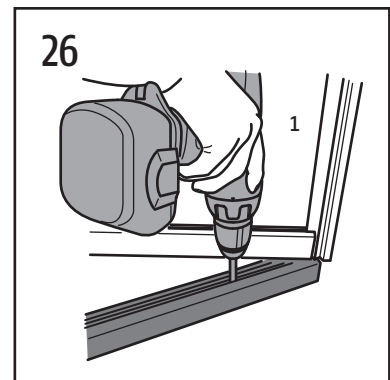

• Open swivel panel slightly and place attachment in front of the end positioning stud.  
• Next fixing between 2.+ 3. positioning stud.

• Now you can attach the floor rail by additional drill holes at intervals of approx. 400-500 mm to the structure.

## 04. Fitting the panel

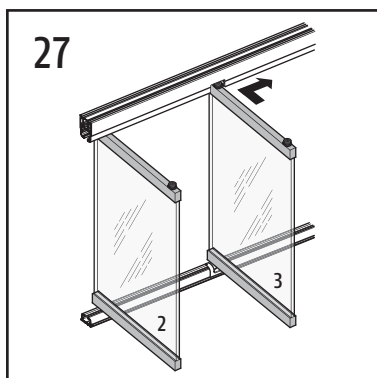

Ensure point 06 is implemented before carrying out test!

• Now insert the panels as shown in the diagram in the rail in the prescribed order (e.g. for a three panel installation first 3 and then 2) .

• Rescrew limiter (259965).



## 05. Inset floor rail (optional)

# SUNFLEX

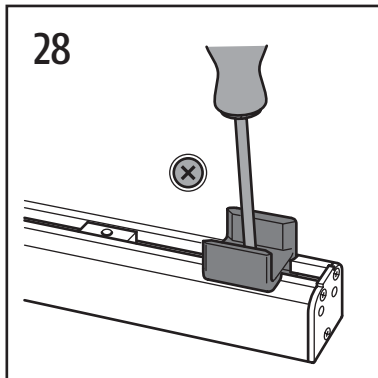

- Unscrew guide block (259924).

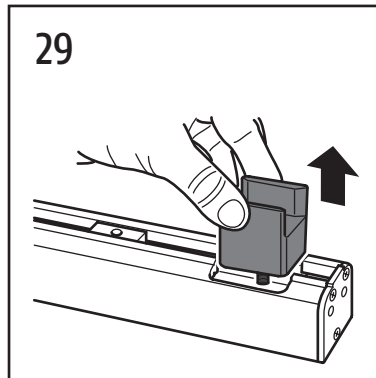

- Remove guide block (259924).

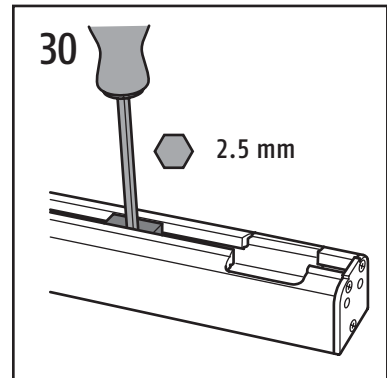

- Unscrew delimiter (259965) with 2.5 mm Allen key.

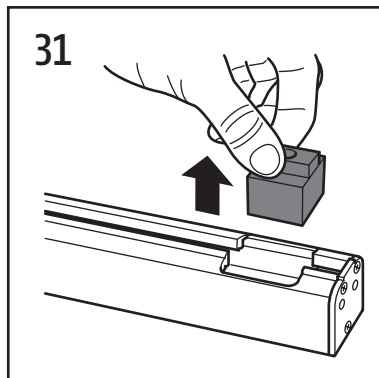

- Remove delimiter (259965).

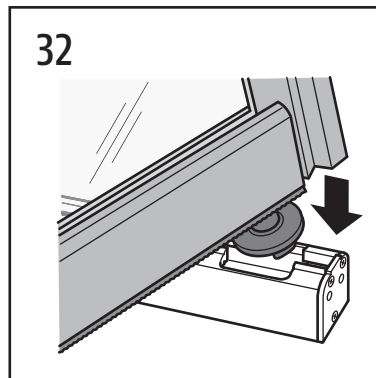

- Insert swivel bearing (258801) of the swivel panel through the opening in the floor rail.

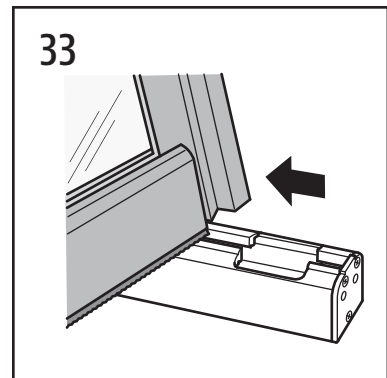

- Guide swivel panel towards the upper recess.

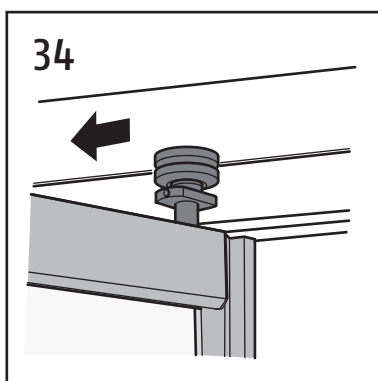

- Slide upper swivel bearing (258804) towards upper recess next to the ceiling rail.

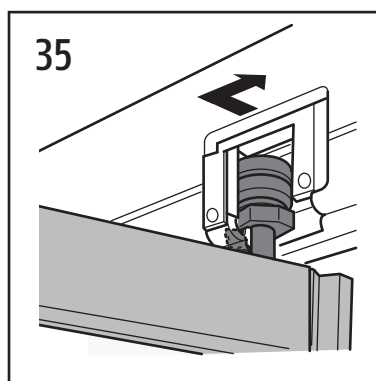

- Insert the swivel bearing (258804) through the recess at the top of the ceiling track. The bar must point towards to the opening direction. (observe position of bar, see Fig. 36).

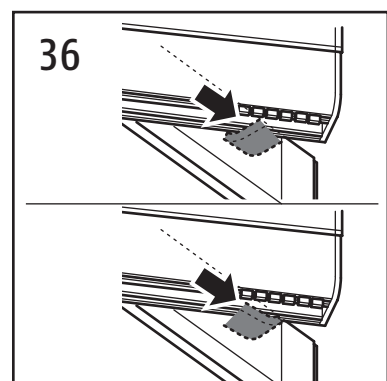

- Bar is positioned 90° to rail.

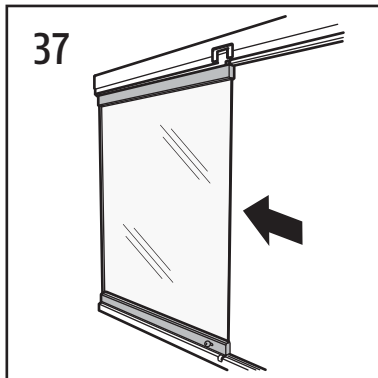

37

- Slide swivel panel lengthways up to last hinge.

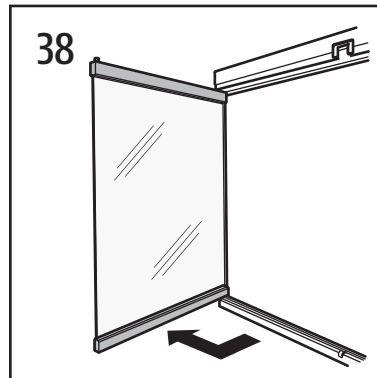

38

- Slide panel towards hinge whilst turning.

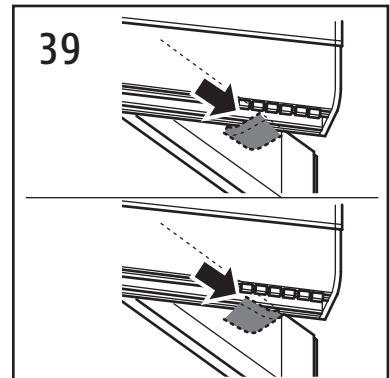

39

- Turn bar 90° inwards (towards recess) until it is positioned lengthwise in the rail.

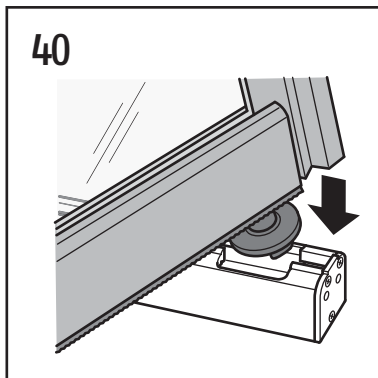

40

- Insert swivel bearing of panel 2 through the opening in floor rail and slide towards hinge.

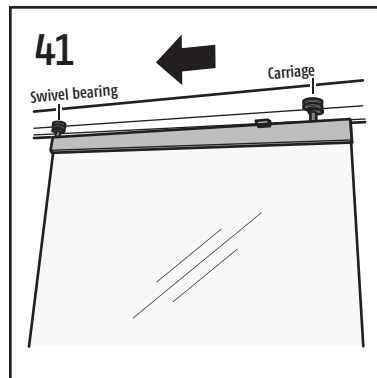

41

- Guide swivel bearing and carriage parallel to the top rail towards the hinge.

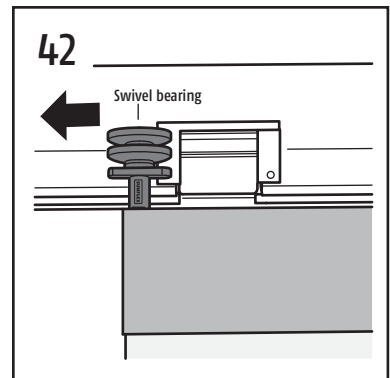

42

- Guide swivel bearing (258803) past the recess towards hinge.

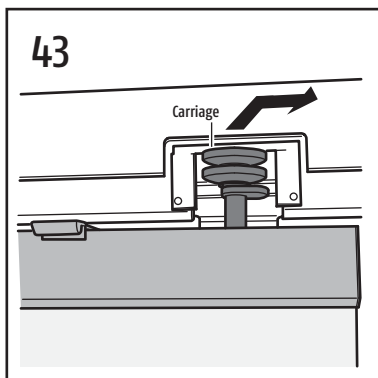

43

- Insert carriage into recess and then move panel 2 away from hinge.

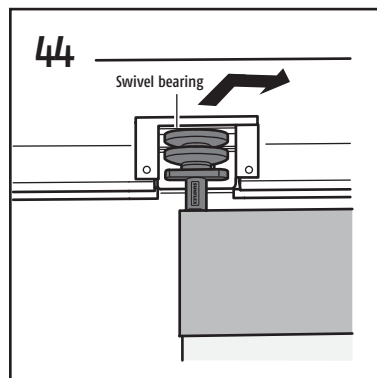

44

- Insert swivel bearing into recess and slide panel 2 to the end of the rail.

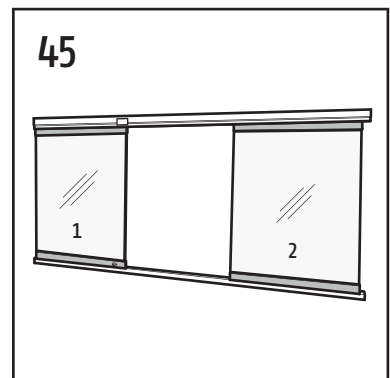

45

- Installation is positioned as shown and is aligned according to instructions (Fig 46).

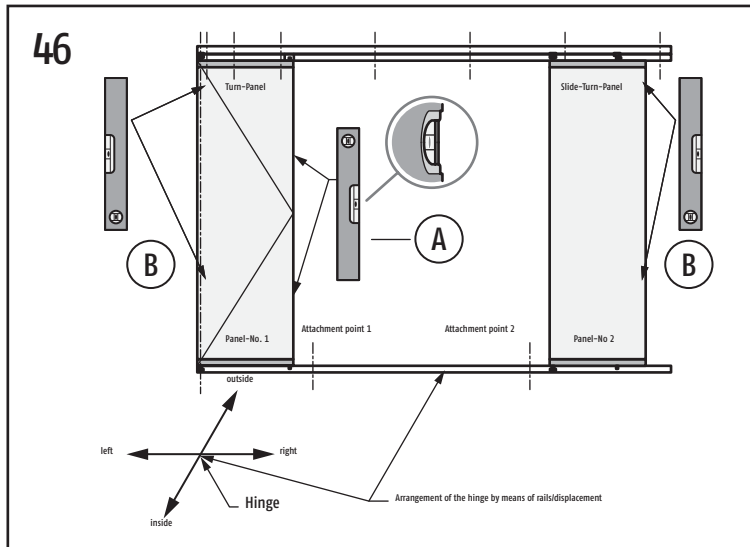

A = Movement right/left by means of spirit level on glass edge and by laying the floor rail on the wall side.

B = Movement inside/outside by means of spirit level on glass edge right and left.

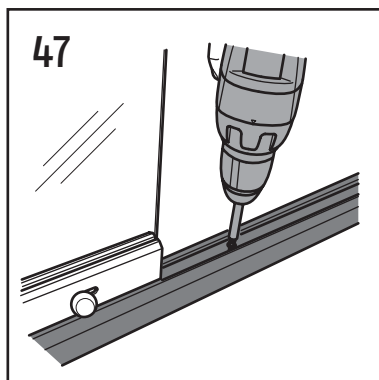

- Attachment of floor rail next to closed panel 1.

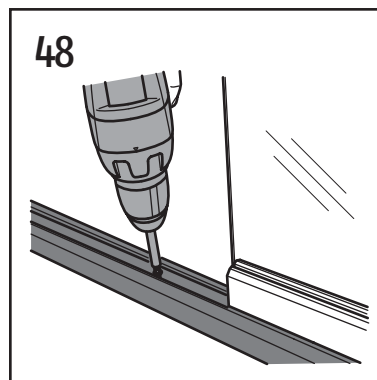

- Attachment of floor rail next to closed panel 2.

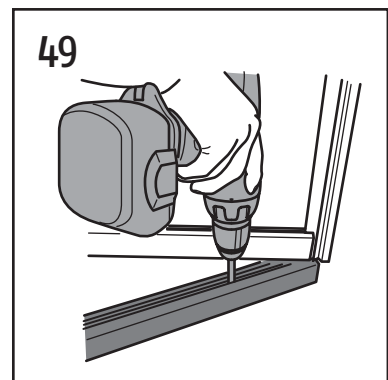

- Open swivel panel slightly and place attachment in front of the end positioning stud.
- Next fixing between 2.+ 3. positioning stud.

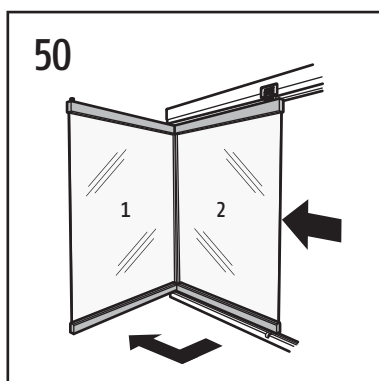

- Open panel 2, press towards hinge whilst twisting open.
- Fit panels 3, 4, 5 and proceed as for panel 2.

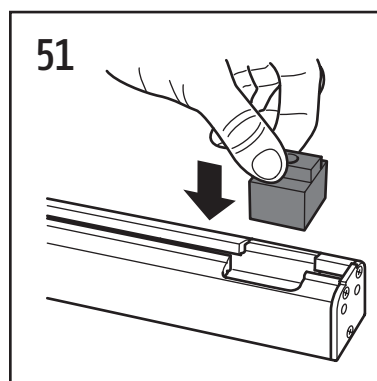

- Fit recess components above (see Page 9).
- Fit delimiter, slide against swivel bearing of last panel and screw.

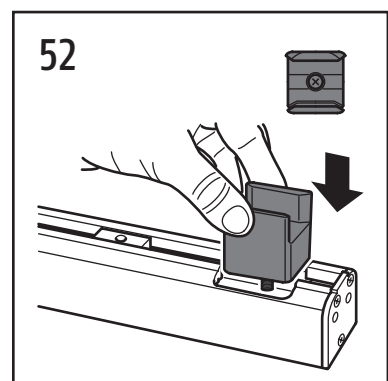

- Insert guide block and screw tight.
- Wide face outside, narrow face inside!

## 06. Assembly of the guide elements

# SUNFLEX

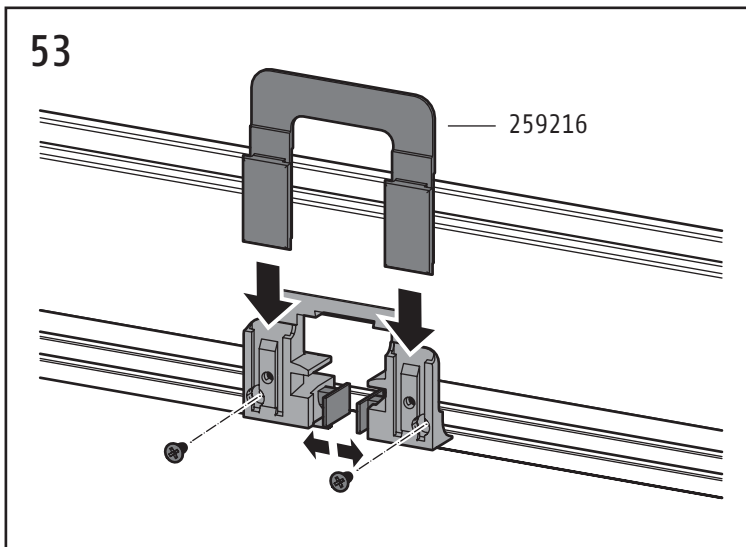

• Assemble as shown in the illustration.

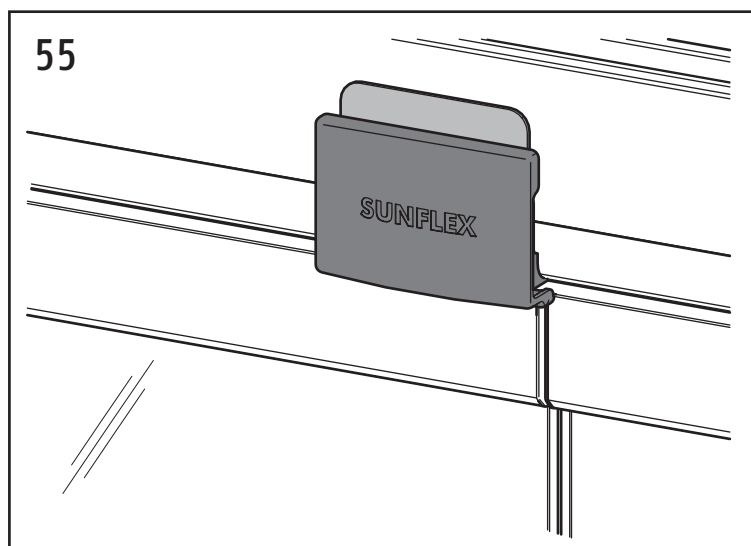
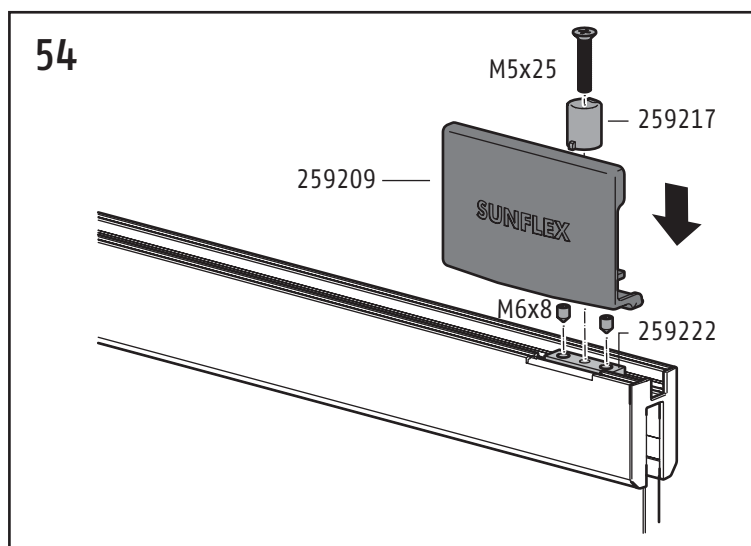

## 07. Adjustment

### Without height adjustment profile:

- If the upper and lower glass retaining profiles are not exactly matched to each other this can be compensated for by fitting spacers under the upper rail (similar to adjustment with the height compensation profile).

### With height adjustment profile:

- Set the swivel panel to a height that allows a 5 mm gap to appear between the panel and the guide rail. To do this use the furthestmost adjusting screw above the swivel point of the swivel panel. Now slide the second panel towards the opened swivel panel. Check that panel 2 butts up against panel 1 both above and below (swivel bearing against swivel bearing). This can be adjusted via adjusting screw 3 adjacent to the recess between panels 1 and 2.

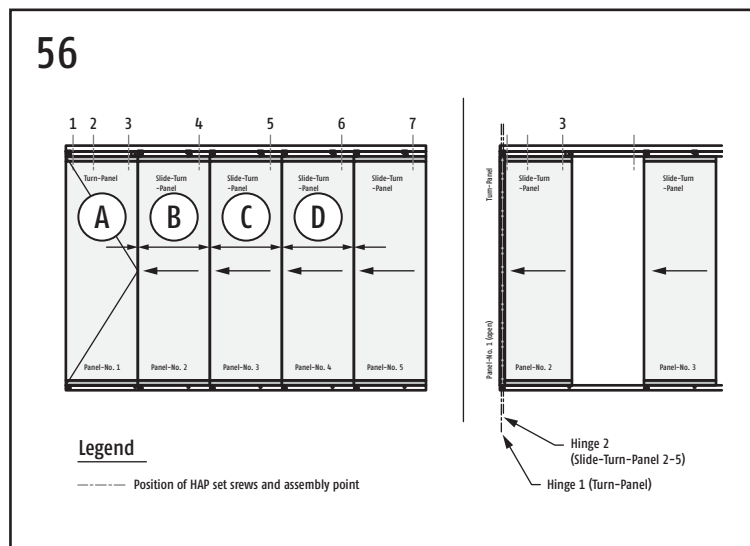

When adjusting the rail always re-adjust the additional support screw (screw 2) in the centre of the first panel.

### Explanation of adjusting screw use:

Adjusting screw 1: This adjusting screw determines the clearance to the floor rail.

Adjusting screw 2: Auxiliary screw for load bearing. **Not an adjusting screw!!!** It must only be slightly tightened in order to retain load-bearing capability.

Adjusting screw 3: This screw is used to set the parallelism of hinge 1 and hinge 2.

**Caution:** If this setting is incorrect the mechanism may be damaged!

Adjusting screw 4: This adjusting screw sets the parallelism of gap A

Adjusting screw 5: This adjusting screw sets the parallelism of gap B

Adjusting screw 6: This adjusting screw sets the parallelism of gap C

Adjusting screw 7: This adjusting screw sets the parallelism of gap D

## 08. Accessory assembly

# SUNFLEX

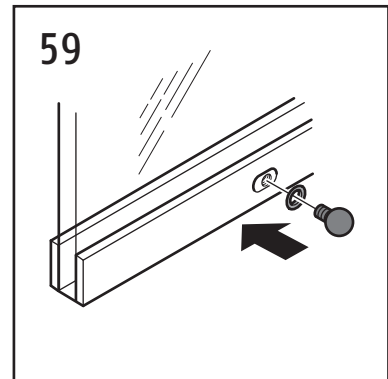
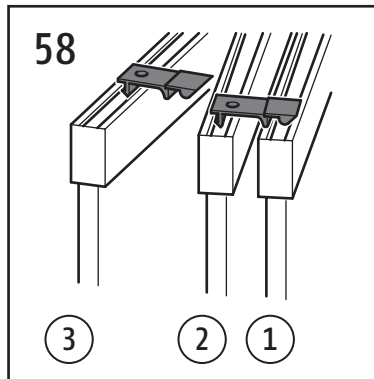
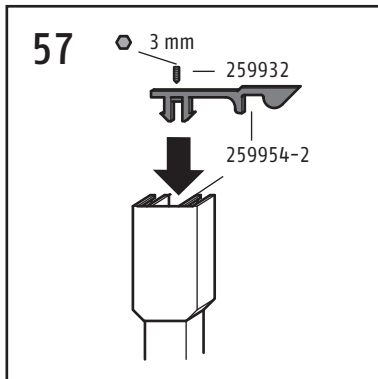

- The supplied panel rails (259954-2) are fitted to the upper section of the panel as shown in Fig. 57.
- These panel clips ensure that the panels are secured to each other when open as shown in Fig. 58.
- Arrange panel clips in offset positions.
- Push the insulation bush over the grub screw. Now screw the complete unit into the lower locking slide. Screw into the slide bar ensuring that the slide remains free to move.
- As shown in Fig. 59 the slide is secured by screw tight.

## 09. Assembly of seal reception profile

**SUNFLEX** 

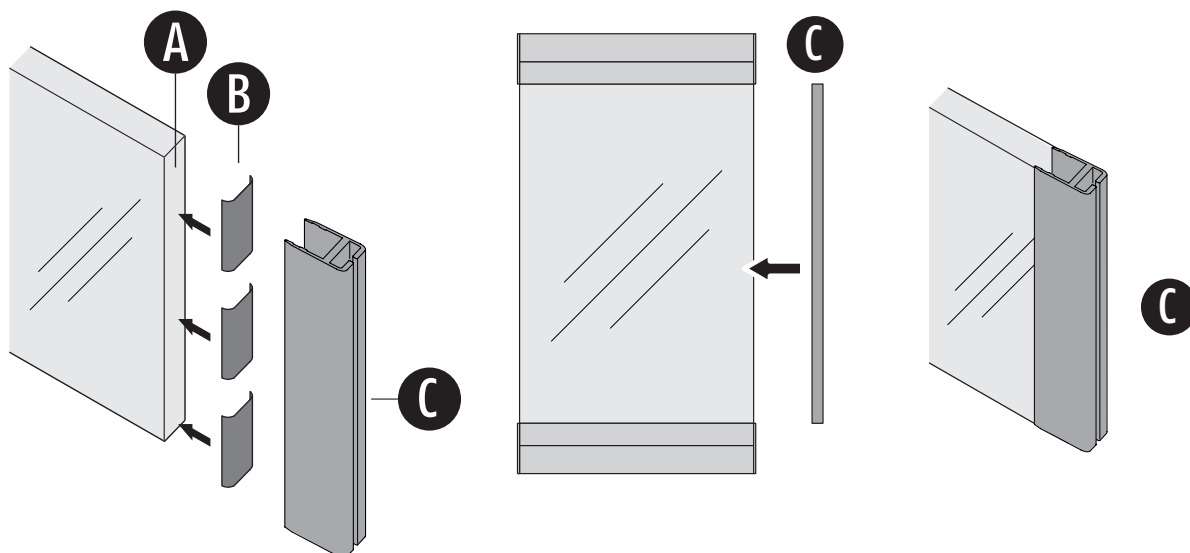

- Ⓓ 1. Silikonzuschnitt (B) auf die Glaskante (A) kleben
- Ⓔ 1. *Glue silicone blank (B) onto glass edge (A)*
- Ⓕ 1. *Coller la découpe de silicone (B) sur le bord du vitre (A)*
- Ⓖ 1. *Silikoonstrip (b) op de glaskant (A) plakken*
- Ⓔ 1. *Pegar la cinta de silicona (B) en el borde del cristal (A)*
  
- Ⓓ 2. Silikon Punkte in die Dichtungsaufnahme (C)
- Ⓔ 2. *Apply silicone dots into the seal reception profile (C)*
- Ⓕ 2. *Etaler des taches de silicone dans le profilé de réception du joint (C)*
- Ⓖ 2. *Silikonpuntjes in het afdichting profiel (C)*
- Ⓔ 2. *Acumular puntos de silicona dentro del perfil (C)*
  
- Ⓓ 3. Dichtungsaufnahme (C) an das Glas (A) andrücken
- Ⓔ 3. *Press seal reception profile (C) to the glass (A)*
- Ⓕ 3. *Appuyer le profilé de réception du joint (C) contre le verre (A)*
- Ⓖ 3. *Afdichtingprofiel (C) aan het glas (A) aan duwen*
- Ⓔ 3. *Apretar perfil de portajunta (C) contra el borde del cristal (A)*
  
- Ⓓ 4. Die Dichtungsaufnahmen werden in Richtung Wand befestigt und dienen als Wandabschluß.
- Ⓔ 4. *The seal reception profiles are fixed to the wall and serve as wall connection.*
- Ⓕ 4. *Les profilés de réception du joint sont fixés au mur est servent de raccordement mural.*
- Ⓖ 4. *De afdichtingprofielen worden in muur richting geplaatst, en dienen als muuraansluiting.*
- Ⓔ 4. *El perfil se monta al final del sistema y sirve de conexión lateral a la pared.*

## 10. Safety instructions



- Risk of injury by falling through open windows.

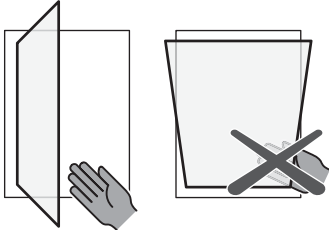

- Risk of injury by trapping of body parts.

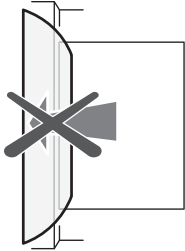

- Risk of injury and material damage by pressing the panel against the opening edge.

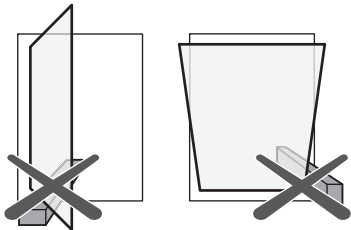

- Risk of injury and material damage by placing obstacles between panel and frame.

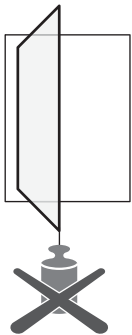

- Risk of injury and material damage due to additional load at the panel.

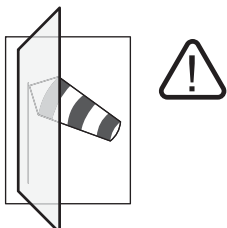

- Risk of injury by wind action.



## 11. Handling

# SUNFLEX

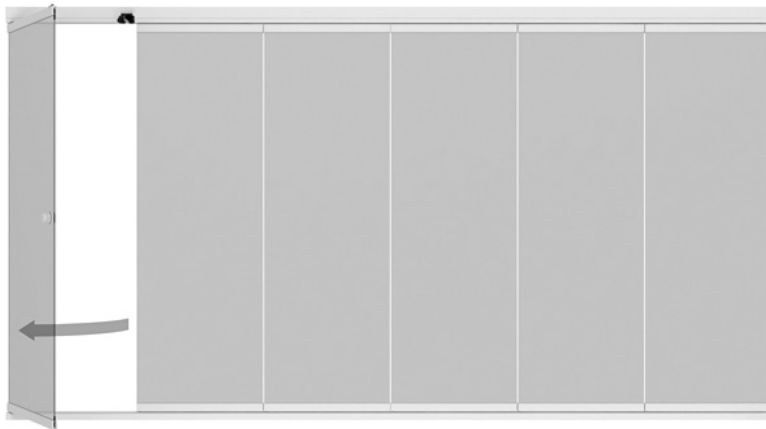

Simple opening by operation of a turn knob

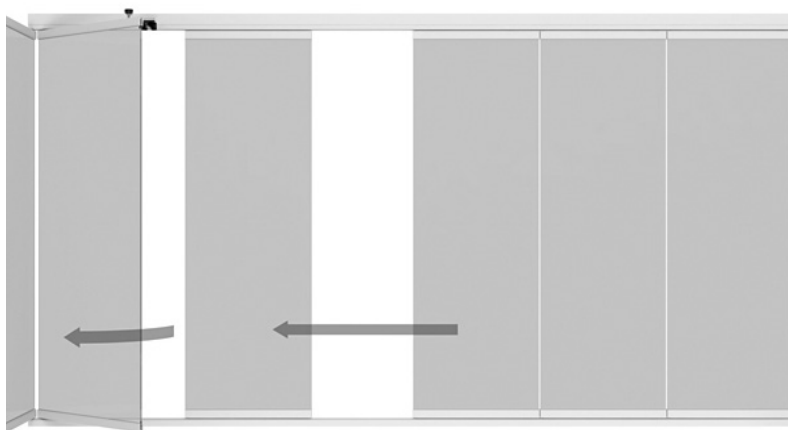

Easy sliding and turning of the individual elements

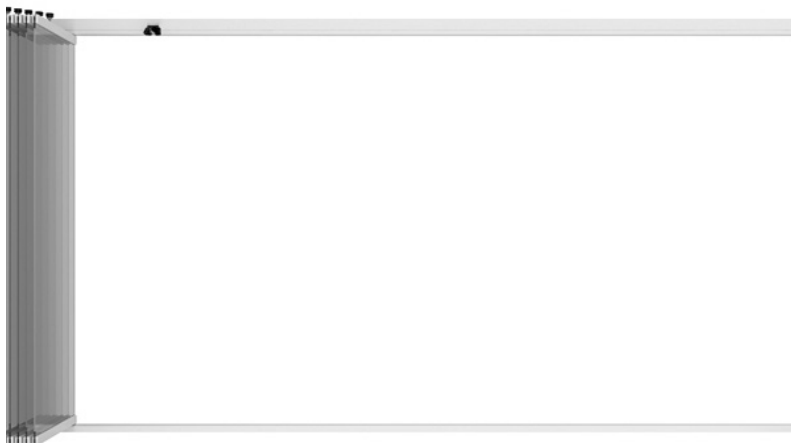

Parking the elements

## 12. Maintenance and servicing instructions



### General

External building parts are not only subject to the weather, but also increased stress caused by smoke, industrial fumes and aggressive airborne dust. In conjunction with rain and dew, deposits of these substances may affect the surface and change the appearance. External parts must therefore be cleaned (at least twice annually or more frequently depending on the degree of contamination) to avoid possible settling of deposits. The sooner you remove dirt from the surface, the easier it is to clean. Observe the safety instructions and instructions for use of the respective servicing and cleaning products. When cleaning do not use a material with an unknown composition. If you are not certain about the effect of the cleaner, then test it first by cleaning a visually unimportant, non-exposed portion of the component.

### Fittings

All fittings must be regularly checked for tightness and wear. Attachment screws must be tightened and defective parts replaced as required. In addition, at least once a year, all moving and sliding fittings must be lightly greased with fitting grease. Only servicing and cleaning agents that do not affect the corrosion protection of fittings should be used.

### Glass surfaces

Dirty glass surfaces can be cleaned using water and a sponge or cloth, etc. Commercially available non-abrasive glass cleaners (such as Ajax, Pril, etc.) can be added to the water. Stubborn stains such as paint or tar splashes should be removed with methylated spirits or white spirit.

#### Caution!

Do not use alkaline caustic solutions, acids, and fluoride-containing detergents to clean glass surfaces.

#### Caution!

A suitable protective film should be used to protect the glass surface against mortar spattering, cement slurry, sparks or weld spattering from partitioning screens and stone-facade acidic-cleaner..

### Seals

All seals must be cleaned and lubricated at least once a year to ensure good functioning. For this purpose we recommend the use of a seal care product. The care product maintains the suppleness of the seal, thus preventing premature brittleness. Ensure that the seals are not damaged and do not come into contact with solvent materials.

### Aluminium surfaces

Anodizing and powder coating is a highly durable and decorative finishing for aluminium components. To maintain the decorative appearance of such components for decades, the surfaces need to be regularly maintained by means of cleaning twice a year.

### Cleaning anodized surfaces

Cleaning of the surfaces must not take place in direct sunlight, the surface temperature must not exceed 25°C. Use only neutral pH cleaners such as normally diluted washing up liquid. Abrasive or scouring materials must not be used to clean heavily soiled, anodized surfaces – cleaning pastes are available.

## Cleaning powder-coated surfaces

In the same way as for anodized elements, cleaning must be carried out whilst cold (maximum of 25 °C surface temperature). In this case also, use only pH-neutral material. Solvent-based cleaners attack the surface of the powder coating and, like scouring or abrasive cleaners, should not be used. To remove stubborn fat and greasy dirt we recommend aroma-free methylated spirits. This must only be applied for a short time and then rinsed off with clean water. In addition, we recommend treatment with car wax to leave a water-repellent film. Check on a non-exposed area whether the material used has an adverse effect on the shine.

## Wood surfaces on wood/aluminium elements

For the cleaning of internal wood surfaces it is best to use mild detergent such as dilute detergent and soap suds. Since the internal wood surfaces are not subject to wear and weathering by rain and sun light, painting is not required. Avoid abrasive, corrosive and solvent-based cleaners. Use only soft cloths to avoid scratching the paint surface. Window cleaners contain small traces of alcohol and ammonium chloride. These materials are very suitable for cleaning the glass as well as the wood-frame sections. After cleaning, dry the wood profiles with a dry, soft cloth, because extended exposure to alcohol can soften the paint surface.

SUNFLEX Aluminiumsysteme GmbH  
Im Ruttenberge 12  
D-57482 Wenden-Gerlingen  
Tel.: +49 (0) 2762 / 9253-0  
Fax: +49 (0) 2762 / 9253-280  
[info@sunflex.de](mailto:info@sunflex.de)

**SUNFLEX** 

SUNFLEX Aluminiumsysteme GmbH | Im Ruttenberge 12 | 57482 Wenden-Gerlingen | Tel.: +49 (0)2762 9253-0 | Fax: +49 (0)2762 9253-280 | [www.sunflex.de](http://www.sunflex.de) | [info@sunflex.de](mailto:info@sunflex.de)